Designing and Installing High Efficiency Air to Air Energy Recovery

Course No: M01-017

Credit: 1 PDH

Klas Haglid, P.E., R.A.



Continuing Education and Development, Inc.
22 Stonewall Court
Woodcliff Lake, NJ 07677

P: (877) 322-5800
info@cedengineering.com

Designing and Installing High Efficiency Air to Air Energy Recovery

DISCLAIMER

The following is a Best Practices Guide for applying Building Performance Equipment, Inc. ® (BPE) Energy Recovery Modules to an existing K-12 school. BPE, its employees, contractors or subcontractors make no warrant, express or implied, and assume no legal liability for the information in this report; nor does any party represent that the uses of this information will not infringe upon privately owned rights. This report has not been approved or disapproved by any third party entity. Use of this manual signifies that the user will indemnify and hold BPE and its entities harmless for any actions, or actions of others, that result from this guide.

Introduction:

"The average American spends approximately 90 percent of their time indoors. And while most people are aware that outdoor air pollution can damage their health, many do not know that indoor air pollutants can also do the same. Indeed, studies of human exposure to air pollutants by the Environmental Protection Agency (EPA) indicate that indoor levels of pollutants may be 2 to 5 times - and occasionally more than 100 times - higher than outdoor pollutant levels. Indoor air pollutants have been ranked among the top five environmental risks to public health. The problems they cause can be subtle and do not always produce easily recognized or immediate impacts on health." – EPA.

With new technologies, we can improve indoor air quality (IAQ) and can save energy at the same time. One of the big changes with efficiency of air to air energy recovery is the new reverse air flow curve, resulting in very high efficiency inline fans. Traditional energy recovery equipment uses very high pressure drops, small cores and fans that typically take hundreds of Watts of energy, even for a small office or residential application.

When you use a very high efficiency fan, the power consumption, even for a 110 cfm, can be as low as 19 Watts of power. That is less than a 20-Watt light bulb. When you combine these fans with a very good efficiency direct counter flow heat exchanger, we find that you can get fan efficiencies as high as 0.2 Watts/cfm. This is much better than the traditional 5 to 10 Watt/ cfm. This is a very large improvement in energy efficiency. The overall rating of energy recovery equipment can be defined as the Energy Efficiency Ratio (EER). This is the Btu's of heating and cooling energy recovered for the Watts of total power consumed by the Energy Recovery Ventilation (ERV) system, which can be well over an EER of 60. When we evaluate ERV's, we typically use the American Society of Heating and Refrigeration Engineering (ASHRAE) Standard 84 and this has also been defined further by the Air Conditioning, Heating and Refrigeration Institute (AHRI) as Standard 1060 for the testing of air to air energy recovery.

When using this equipment you are trying to meet two main ANSI/ASHRAE Standards: 62.1 (Ventilation for Acceptable Indoor Air Quality) and 90.1 (The Energy Efficiency Standard). These two standards are almost contradictory. The ventilation standard 62.1 dictates using more energy to precondition more outdoor air, which takes a lot of energy. The goal of Standard 90.1 is to reduce energy consumption in a building. The best way to meet both of these standards without increasing energy consumption is by using very high efficiency air to air energy recovery with very high efficiency fans. Typically, a standard compliant exhaust fan can be replaced with an ERV and two high efficiency fans, resulting in the decrease of power consumption. We have demonstrated this to work very well in many different applications.

What we will be focusing on in this course is how to actually install an energy recovery module, either in a residential setting with a drop ceiling or in a classroom type environment. Typically, these installations are fairly easy since you are basically removing replacing ceiling tiles with 2'x2' supply and returns vents and then attaching them to the fans and the ERV. It

can be noted, in order to get a very good performance out of a heat exchanger or an ERV, you need at least 5 to 10 duct diameters downstream from the fans to allow the flow profile to become uniform and the ERV device to work more efficiently. While there are very good unitary products with built-in fans, typically there is about a 15% efficiency penalty for mounting the fans very close to the unit. If the unit is supplied with the fans, there is no way to get the effective and preferred 10-duct diameters away from the ERV. We have also found that mounting the fans separately, gives much more flexibility in the installation of the ventilation system and reduces equipment weight. The time to install an individual system is usually few hours or about half a work day. There are systems that work completely by plugging together three prong plugs and do not require the use of an electrician. This is usually a do -it-yourself type effort or requires a skilled home improvement type contractor.

The Advanced Energy Design Guide for K-12 School Buildings: Achieving 30% Energy Savings Towards a Net Zero Building, by the American Society of Heating, Refrigerating and Air-Conditioning Engineers, Inc., 2008, recommends using energy recovery ventilators. This guide is intended to provide architects and engineers a blueprint for achieving 30% energy savings towards a Net Zero building in a logical fashion to improve the design process.

Choosing the Right Size ERV for Your Building:

Ventilation is one of the most influential HVAC aspects of a school building or small office in terms of occupants' comfort and energy costs. Not only does ventilation affect a substantial part of O&M costs, but more importantly, it affects student performance. Students occupying classrooms with ample ventilation typically score better on standardized testing and have higher attendance rates. In combination, all of these benefits contribute to increased state funding, reduced expenses, and increased budgets for improving the quality of education.

By code, each classroom should have the capacity to supply at minimum 13 cfm/person occupying the room, and 15 cfm/person for younger students (ages 5 to 8). Of course, the majority of schools will not possess the ability to supply such levels of ventilation as they are old and outdated. Regardless of building age, all schools should comply with the up-to-date building codes and standards for an optimal learning environment. By using displacement ventilation and a CO₂ demand ventilation system, the amount of outdoor air can be reduced by 2.5 times, while still providing better IAQ and only when the room is occupied.

Calculation of Minimum Ventilation Rates:

Minimum ventilation rates should always be equal to the sum of the requirements of each zone. With respect to a classroom application, typically one zone will exist. Other zones that will exist within the building include locker rooms, offices, auditoriums and hallways. However, for the purpose of this analysis, ventilation rates will be calculated on a per classroom basis. This approach allows for optimal control and energy efficiency as

ventilation is provided when required and in the appropriate amounts.

The following is a step-by-step process to calculate the minimum ventilation rates:

1. Calculate the Breathing Zone Outdoor Airflow; i.e., the design outdoor airflow required in the breathing zone of the occupied space or spaces in a zone.

Equation 6-1: $V_{bz} = R_p \times P_z + R_a \times A_z$

V_{bz} = breathing zone outdoor airflow, fresh outdoor air in cfm (cubic feet/ minute)

R_p = outdoor airflow rate required per person as determined from Table 6-1 in ANSI/ASHRAE Standard 62.1

As an example:	Classroom	$R_p = 10$ cfm/person
	Restaurant	$R_p = 7.5$ cfm/person
	Meeting Room	$R_p = 5$ cfm/person

P_z = zone population, the largest number of people expected to occupy the zone during typical usage

R_a = outdoor airflow rate required per unit area as determined from Table 6-1 in ANSI/ASHRAE Standard 62.1

As an example:	Classroom	$R_a = 0.12$ cfm/ft ²
	Restaurant	$R_a = 0.18$ cfm/ft ²
	Meeting Room	$R_a = 0.06$ cfm/ft ²

A_z = zone floor area, the net occupied floor area of the zone in ft²

Example: Suppose you have a 1200 square foot area class room with 25 students. What is the needed total CFM of outdoor air?

Using Equation 6-1:

$$\begin{aligned} V_{bz} &= R_p \times P_z + R_a \times A_z \\ &= 10 \text{ cfm/person} \times 25 \text{ students} + 0.12 \text{ cfm/ft}^2 \times 1200 \text{ ft}^2 \\ &= 250 \text{ cfm} + 144 \text{ cfm} = 394 \text{ cfm of Outdoor Air} \end{aligned}$$

We would size this classroom for a 500 cfm ERV that would be run 78% or less of nominal flow for 80% efficiency or better with displacement ventilation. Typically with a CO₂ sensor, the system would only run during a period of active classroom use. For the remaining time the system would be off in set-back mode until triggered to bring in fresh air by the increase of CO₂ generated by the students.

Step-by-Step Installation Instructions:

Select the correct filter for the exhaust grill you are installing.



Check for the proper filter air flow direction. Begin the installation by preparing and assembling the exhaust grill to the flex ductwork. The filter is designed to have a specific orientation which can be identified by an arrow or something similar to Figure 3.



Pull back the insulation on the flex duct and tightly seal the duct to the grill. This was done by using aluminum tape to adhere the two together. Then, to keep it securely in place and to help reduce any strain on the attachment when being installed, a large zip tie was added on top.

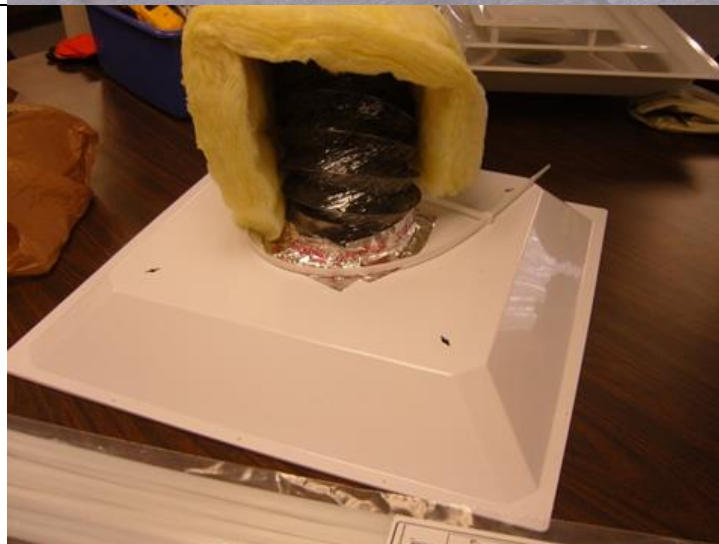

Once adjusted, tighten the zip tie and cut any excess length off. The insulation can now be pulled forward to cover the bare flex duct and zip tied again to keep it in place.



Begin installing the ductwork at the location where the exhaust grill was designed to be. Snake the opposite end from the grill up through the drop ceiling or designated area towards the ERM.



At this time, all of the flex duct will be up in the drop ceiling and all of the kinks should be worked out. If a straight run isn't possible, try to make the bends as smooth and small as possible to keep the pressure drop to a minimum.



Mount the Energy Recovery Module in the drop ceiling or designated area. Most Energy Recovery Modules are difficult to install overhead and in tight spaces because of their weight and size. That is why for this application BPE-XE-MIR 200 was optimal. It is made of Polypropylene and is long and narrow.

Photo courtesy of Building Performance Equipment, Inc.

Despite the ERM are relatively light, they should be kept from resting on the ceiling grid when mounted. This will eliminate any future problems including sagging of the ceiling or any vibration.

Connect the duct work previously run throughout the ceiling to the correct intake or exhaust lips on the ERV. Seal with aluminum tape and secure with a zip tie over the duct work, aluminum tape and ERV lip the same way as connecting the duct work to the filter grill.



Seal the inside lining of the duct work with aluminum tape. Then secure the entire duct work with a zip tie over the insulation, aluminum tape and ERV lip the same way as connecting the duct work to the filter grill.



After the ERV is installed and all the duct work is run, retain a skilled masonry contractor to make penetrations in the exterior concrete wall for exhaust air. Wood framed walls can be penetrated by a hole saw.



Be sure to seal any cracks that are apparent in the exterior walls.



Caulk and seal the weather proof air intake exhaust to minimize water penetration issues.



Fans can be fit between floor joints even in very tight ceilings and then mounted with the supplied bracket into the drop ceiling as well.

FR 150 Fantech high efficiency inline fan.

Photo courtesy of Fantech, Inc.



Duct work should then be connected to the fans and intake/exhaust.



To make for easy installation, install a Building Performance Equipment (BPE) Control Panel.

The control panel will need to be installed in an area with 3-prong outlets to plug in the control box and in the vicinity of the fans in order to be able to plug them in.

Also mount the CO₂ sensor attached to the control panel in an area where it can detect CO₂ when the facility is being used.

Plug in the control box into the outlet and connect the fans to each of the supplied power cords.

Once installed, control the intake and exhaust fans from the control box.



Correct Flow and Installation:

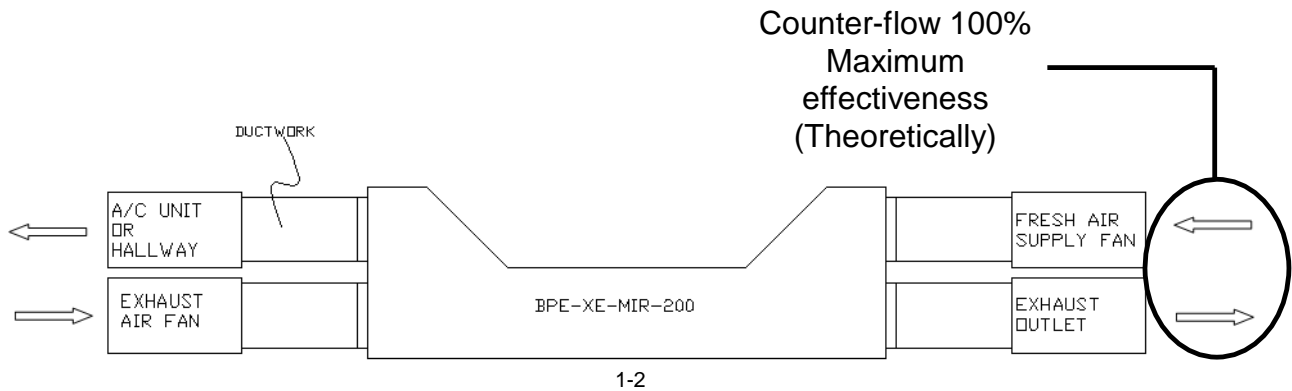

****Note:** Exhaust and supply airflows should be counter flow for maximum efficiency.

Incorrect Flow and Installation:

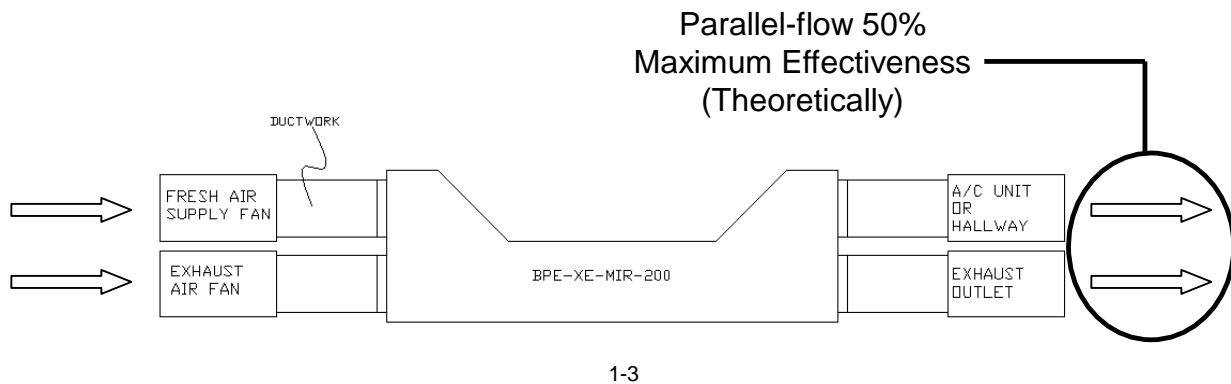

*****NOTE:** This is an example of **WHAT NOT TO DO**. If the airflows are headed in the same direction, it will work, but not nearly as efficiently.

Installation:

BPE Energy Recovery Ventilators are easy to install and can be 90% effective if designed properly. Typical installation time is less than 4 hours in most applications.

Supplies:

- (1) BPE Direct-Counter flow Air-to-Air Heat Exchanger (Recommended quantity and series for your specific project should be by the local representative)
- (2) High Efficiency Inline Fans (1 for each airstream, exhaust and intake)
- (2) 6" dryer vents, with dampener removed from supply side
- (1) 2'x2' Drop Ceiling Supply with 6" duct connection
- (1) 2'x2' Drop Ceiling Return with 1" air filter box
- (2) 25' of 6" flex duct
- (1) 25 pack of 2' zip ties
- (1) Tube of 100% silicone caulk

Procedures:

1. Properly mount and secure the ERV in a designated space (e.g. rooftop or in drop ceiling). The ERV shouldn't be a significant distance away from exterior wall vents.

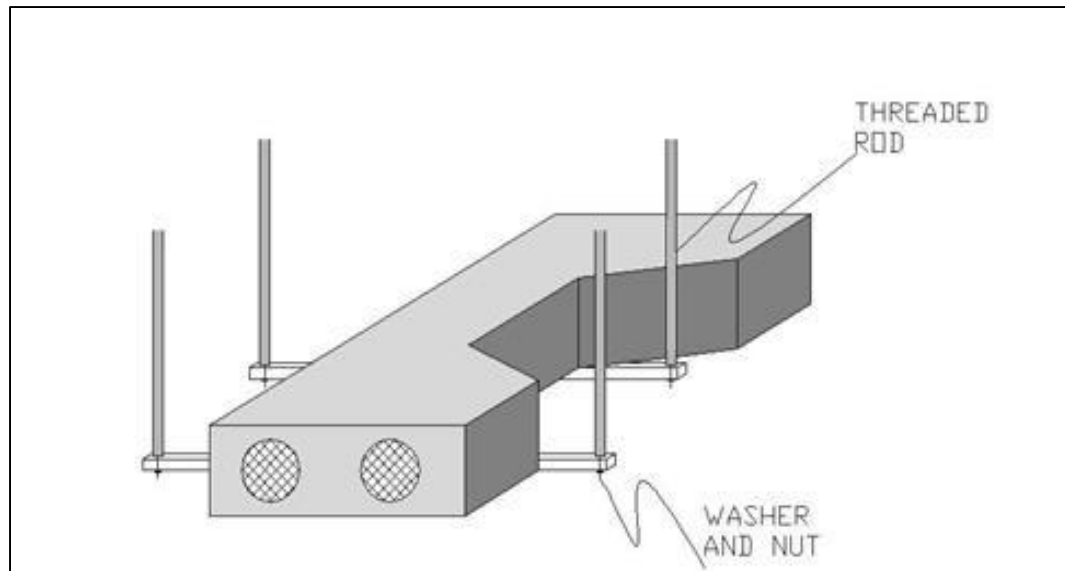

Figure 1

2. Choosing the location of the inlet and outlet:
 - a. For better distribution of fresh air, it is best to separate the two airstreams as much as possible (10 feet minimum by code).
 - b. Exhaust grilles should be installed near or in a room that may have an extreme difference in temperature or humidity, or may have contaminants that negatively affect the indoor air quality (e.g. kitchen or bathroom).

Note: If there is already an existing ventilation system throughout the building, then the fresh air preconditioned by the ERV can just be incorporated into the existing return duct.

3. Install supply and exhaust fans as shown in Figure 2.



Figure 2

Here we see the location of one of the inline fans installed in a drop ceiling in a classroom. Note that it is a metal fan that is mounted on the metal framing, with wiring applied using armored cable.

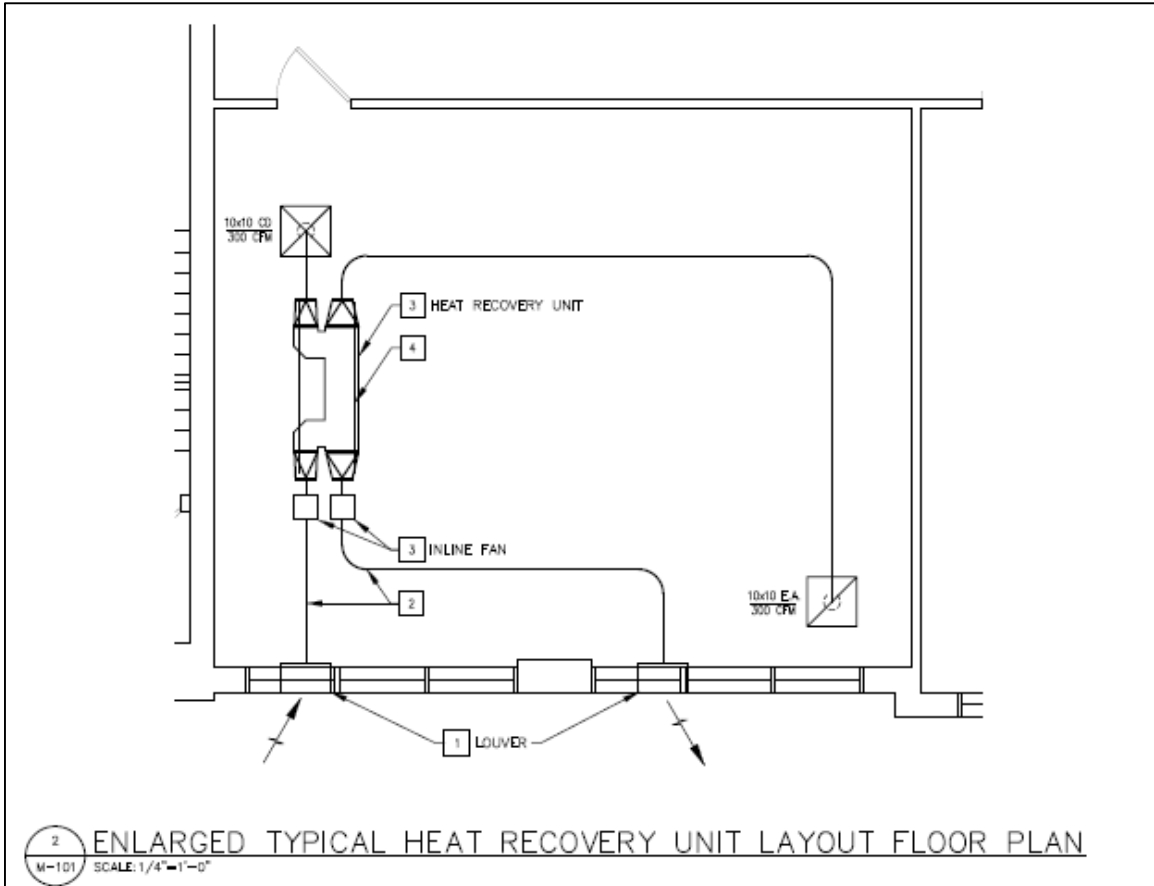

Figure 3

Figure 3 above demonstrates good separation, in excess of 15 to 20 feet, between the airflows. A ten foot minimum is recommended between the fresh air intake and exhaust. The air being brought in is coming through the top of the BPE unit as shown above and taken to the back left corner of the classroom. The air being exhausted out of this area is in the farthest corner from the fresh air intake which is in the bottom right corner of the figure. This provides a very good separation between the intake and the exhaust and allows for good displacement ventilation.

Independent ASHRAE peer reviewed publications hold the general consensus that displacement ventilation can be up to two and a half times efficient as opposed to dilution practices, which can typically occur when supply and return grilles/diffusers are not separated evenly or at recommended distances.



Figure 4

Figure 4 depicts a BPE-XE-MIR 500 mounted in a ceiling area where it is placed up between the metal trusses that are supported by two metal rods. The rods are bolted and anchored in place and hold the BPE unit firmly in place.



Figure 5

Figure 5 depicts another fan that is also up in the ceiling area tied in with its mounting bracket and bolted into place. The fan should be placed firmly in a location such that there is no vibration or noise generated from the operation of the fan.

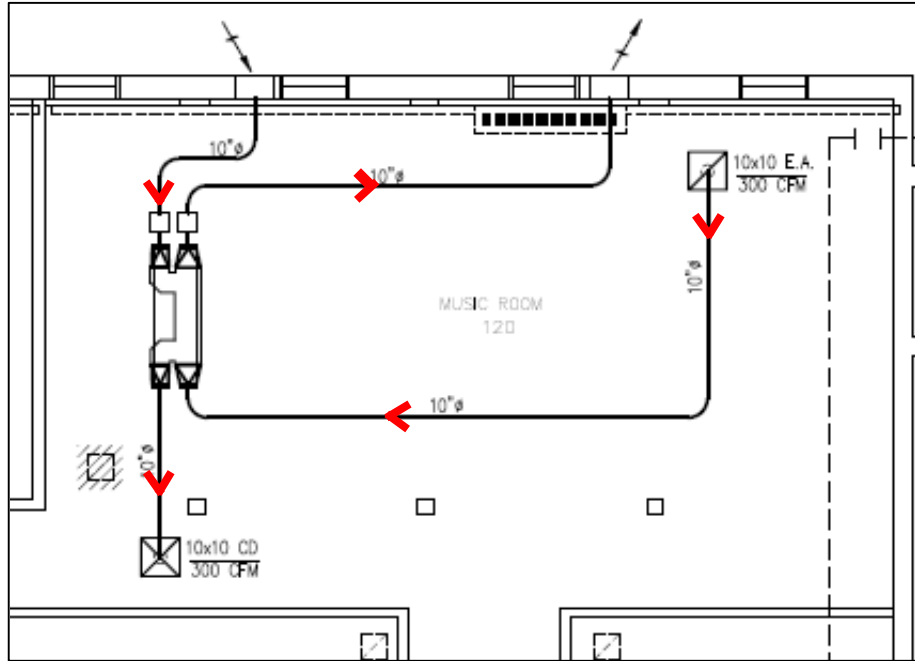

Figure 6

Figure 6 illustrates the proper design of a BPE-XE-MIR-500 serving two classrooms with a possible dividing wall. In order to provide displacement air ventilation, air is taken and provided at two extremes allowing for unidirectional flow of fresh air. The advantage of using one larger unit for several different areas is that you improve overall efficiency, especially when the system is controlled using a CO₂ sensor for common areas.

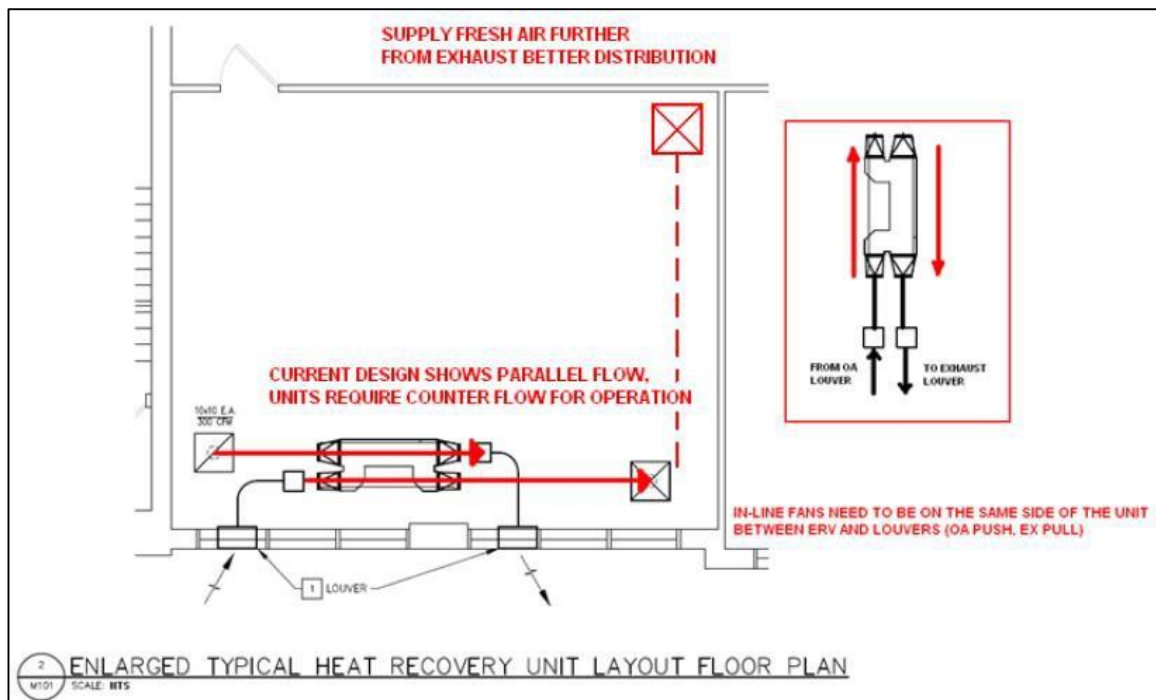

Figure 7

Figure 7 reveals a prime example of **What Not To Do with BPE Ventilator Modules**. Although this case looks like a good application, there are two main problems.

First, there is poor separation between the intake and the exhaust. The air is basically being pulled from the front left corner while fresh air is pushed into the front right corner of this classroom. This configuration will have a tendency to pull air through the front of the classroom where the teacher sits, but the students in the back will not receive the benefit of fresh air. Our recommendation would be to move the supply air on the bottom right of this drawing to the back of the classroom (as shown by the red dotted lines).

Second, the BPE Ventilator Module is not in a counter-flow operation; it is concurrent flow. Concurrent flow (or parallel flow) will have a tendency to provide 50% thermal effectiveness whereas counter-flow technology has a tendency to be up to 99% thermally efficient. Changing this flow path is relatively easy to do; simply reverse one flow path.

If the BPE unit is placed between the intake and the exhaust in the proper location as shown previously, it is easy to avoid this problem. This is probably the most common installation mistake that occurs. With counter-flow and over 80% thermal effectiveness, the requirements of ASHRAE Standard 55 can easily be met. Human comfort, energy conservation and good use are very beneficial.

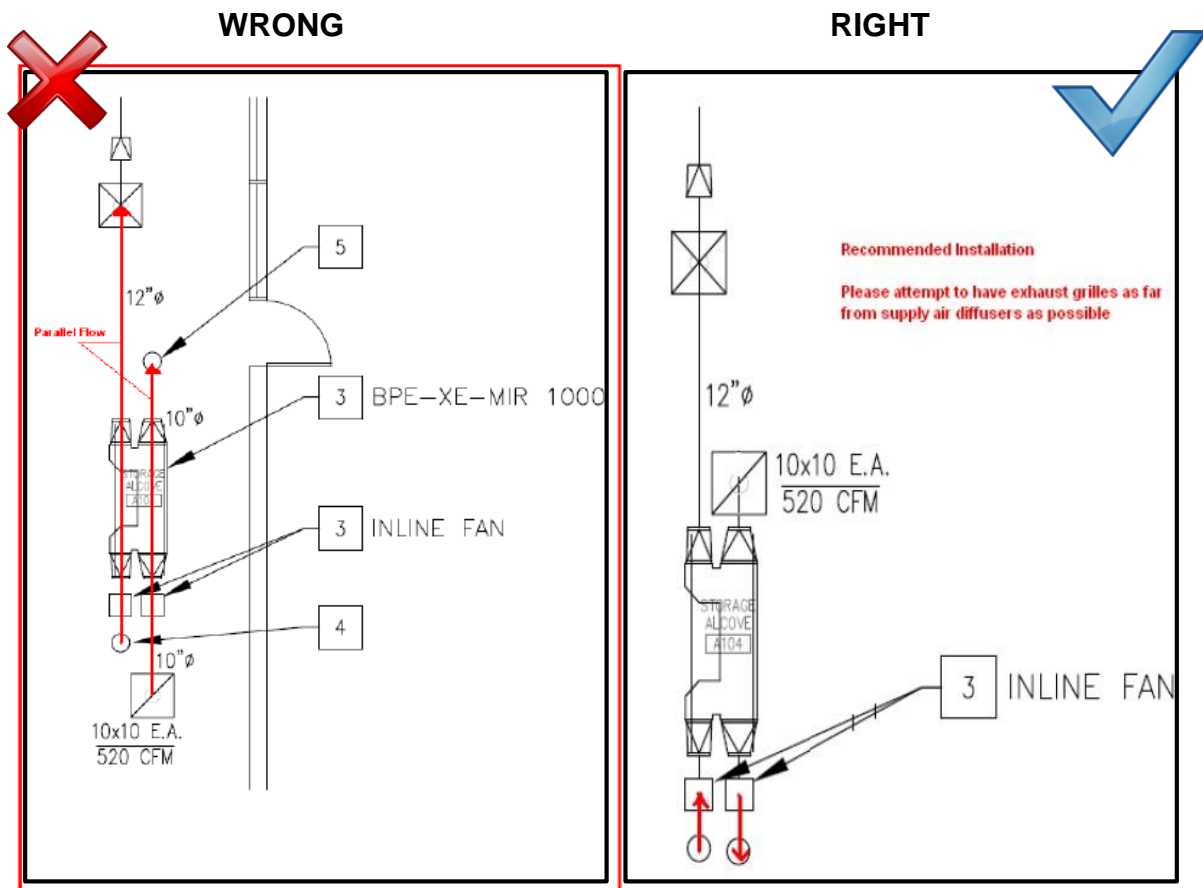

Figure 8

The figure on the left shows concurrent flows where both airstreams are running in the same direction, which reduces the effectiveness of the equipment by 50%.

The figure on the right shows counter-flow airstreams which allows the equipment to function at its full capacity.

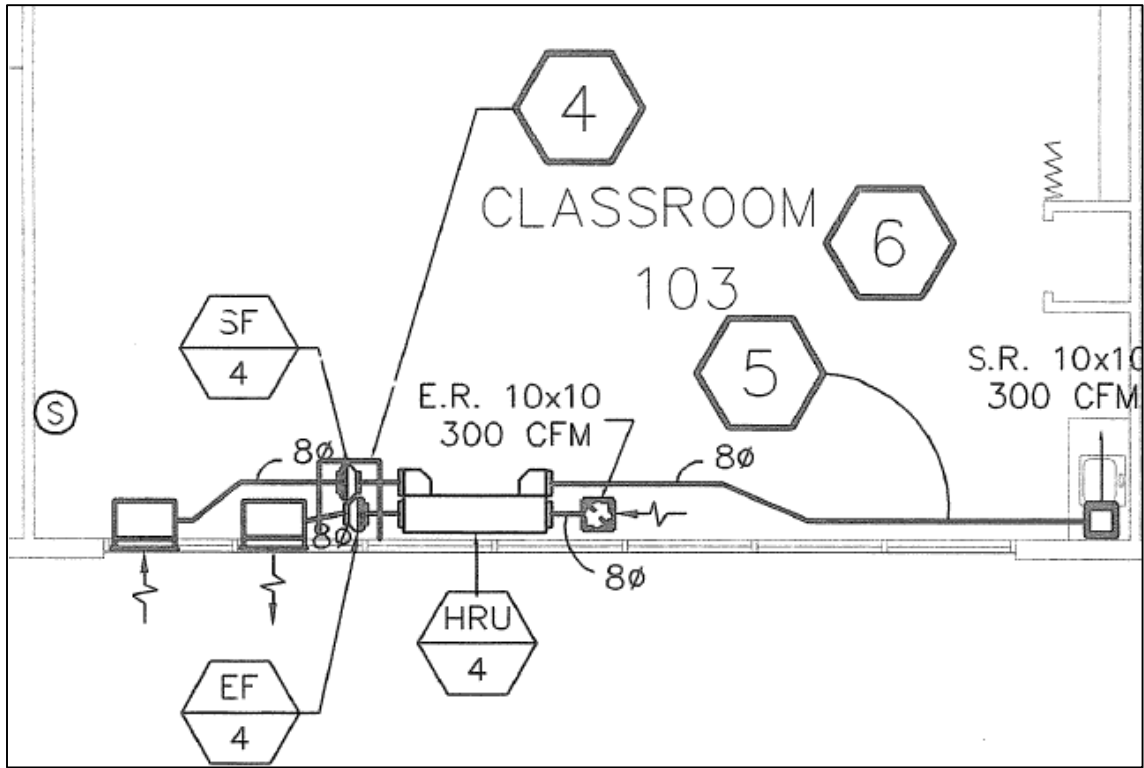

Figure 9

Figure 9 depicts an example of a standard layout for a classroom. Here we see the air being brought in through the fresh air side of the BPE unit and delivered to one side of the classroom and then being shot across the classroom while exhaust air is being brought through the unit. This is typically used when a drop ceiling in a classroom is very shallow or nonexistent and the unit is put into a box or soffit in the area of the exterior windows or walls.

This can be a very inexpensive and effective way of installing an energy recovery module and can take the place of a standard under-the-window unit ventilator. Typically the air intake for this type of application is at least ten feet off the ground. We have found through testing that the air quality at this height is much better, has less contaminants and has much less pollen than the air being pulled at ground level.

Definitions:

Airstream Surfaces: All airstream surfaces in equipment and ductwork in the heating, ventilating, and air-conditioning system shall be designed and constructed to be resistant to erosion.

ANSI/ASHRAE: American National Standards Institute/American Society of Heating and Refrigeration Engineering.

ANSI/ASHRAE Standard 62.1-2010, supersedes Standard 62.1-2007. It is ASHRAE's standard for indoor air quality for commercial buildings. The 2010 revision adds new minimum filtration/air-cleaning requirements, minimum requirements for when ventilation systems must be operated, and a Natural Ventilation Procedure.

ANSI/ASHRAE Standard 62.2 – 2010, defines the roles of and minimum requirements for mechanical and natural ventilation systems and the building envelope intended to provide acceptable indoor air quality in low-rise residential buildings. It is ASHRAE's IAQ standard for residential buildings.

ANSI/ASHRAE Standard 55 – 2010, defines the range of indoor thermal environmental conditions acceptable to a majority of occupants, but accommodates an ever increasing variety of design solutions intended both to provide comfort and to respect today's imperative for sustainable buildings.

ANSI/ASHRAE Standard 90.1-2007, Energy Standard for Building Except Low-Rise Residential Buildings, 2007

ASHRAE Advanced Energy Design Guide for K-12 School Buildings: Achieving 30% Energy Savings Towards a Net Zero Energy Building, Published by ASHRAE 2008. Energy costs typically account for 16% of a district's "controllable" costs. This Guide will help your facilities staff designs new construction, renovations, remodeling and modernization projects that use substantially less energy-at least 30% less-than those built to minimum energy code requirements. Achieving this 30% target is not only possible, but easy, and the Guide includes case studies that show schools around the country that have achieved or exceeded the target.

Bird Screens: All outdoor air intakes shall include a screening device designed to prevent penetration by a 0.5 in. diameter probe. The screening device material shall be corrosion resistance. The screening device shall be located, or other measures shall be taken to prevent bird nesting within the outdoor air intake.

Designing for Air Balancing: The ventilation air distribution system shall be provided with a means to adjust the system to achieve at least the minimum ventilation airflow as required by ASHRAE Standard 62.1-2007 or local code, whichever is more stringent.

Drainage: Outdoor air ductwork or plenums shall pitch to drains designed in accordance with the requirements of Local, State and Federal building codes.

Exhaust Duct Location: Exhaust ducts that convey potentially harmful contaminant shall be negatively pressurized relative to spaces through which they pass, so that exhaust air cannot leak into occupied space; supply, return, or outdoor air ducts; or plenums.

Location: Outdoor Air intakes, including doors and windows, shall be located such that the shortest distance from the intake to any specific potential outdoor contaminant source shall be equal to or greater than the separation distance listed in Table 5-1, Air Intake Minimum Separation Distance, of ASHRAE Standard 62.1 – 2007.

Maintenance: Suitable access door should be provided to filters and equipment to permit cleaning.

Outdoor Air Intakes: Ventilation system outdoor air intakes shall be designed in accordance with the following:

Plenum Systems: When the ceiling or floor plenum is used both to recirculate return air and distribute ventilation air to ceiling-mounted or floor-mounted terminal units, the system shall be engineered such that each space is provided with its required minimum ventilation airflow.

Rain Entrainment: Outdoor air intakes that are part of the mechanical ventilation system shall be designed to manage rain entrainment. Outdoor air intakes should be designed for 400 fpm for flows of 7,000 cfm or greater and 300 fpm for flows below that range. FPM shall refer to the face velocity of outdoor air into the intake or louver in feet per minute.

Rain Intrusion: Air-handling and distribution equipment mounted outdoors shall be designed to prevent rain intrusion into the airstream when tested at design airflow and with no airflow.

Snow Entrainment: Where climate dictates, outdoor air intakes that are part of the mechanical ventilation system shall be designed to manage melted snow blown or drawn into the system.

Ventilation System Controls: Mechanical ventilation systems shall include controls, manual or automatic, that enable the fan system to operate whenever the spaces served are occupied. The system shall be designed to maintain the minimum outdoor airflow as required by Section 6 of ASHRAE Standard 62.1 – 2007 or local code, whichever is more stringent.

References:

ANSI/ASHRAE Standard 62.1-2010, Ventilation for Acceptable Indoor Air Quality

ANSI/ASHRAE Standard 62.2 – 2010, Residential Ventilation Standard

ANSI/ASHRAE Standard 55 – 2010, Thermal Environmental Conditions for Human Occupancy

ANSI/ASHRAE Standard 90.1-2007, Energy Standard for Building Except Low-Rise Residential Buildings, 2007

Advanced Energy Design Guide for K-12 School Buildings: Achieving 30% Energy Savings Towards a Net Zero Building, American Society of Heating, Refrigerating and Air- Conditioning Engineers, Inc., 2008